

# ASSEMBLY INSTRUCTION

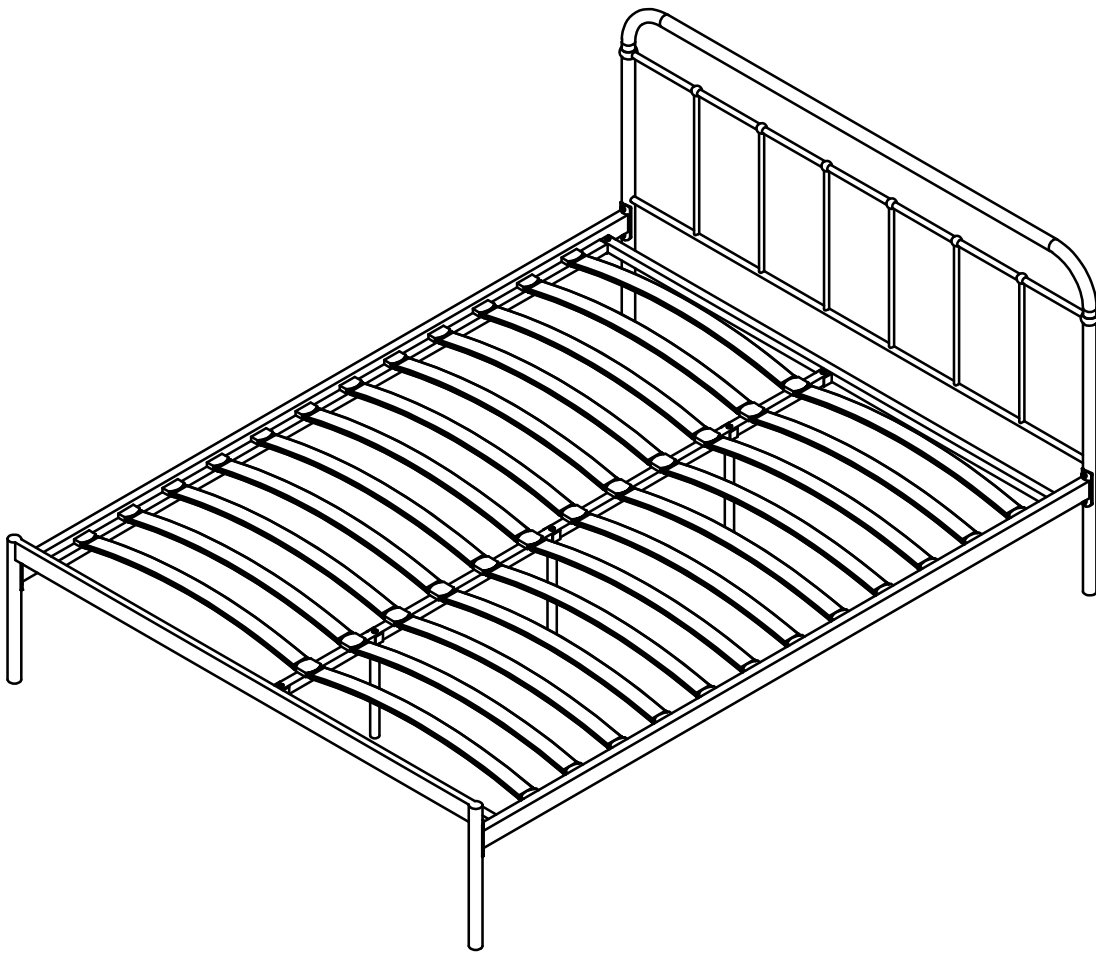

Remarks: Two adults are required to assembly t his bed

Please find in this pack our FAQ guide for this bed should you need it.

We would like to take this time to thank you for choosing Crazy Price Beds, we would love to hear back from you about your experience with us so please leave us a review.

**When it comes to assembling we recommend to check that you have the correct amount of parts against the bed breakdown before starting the frame.**







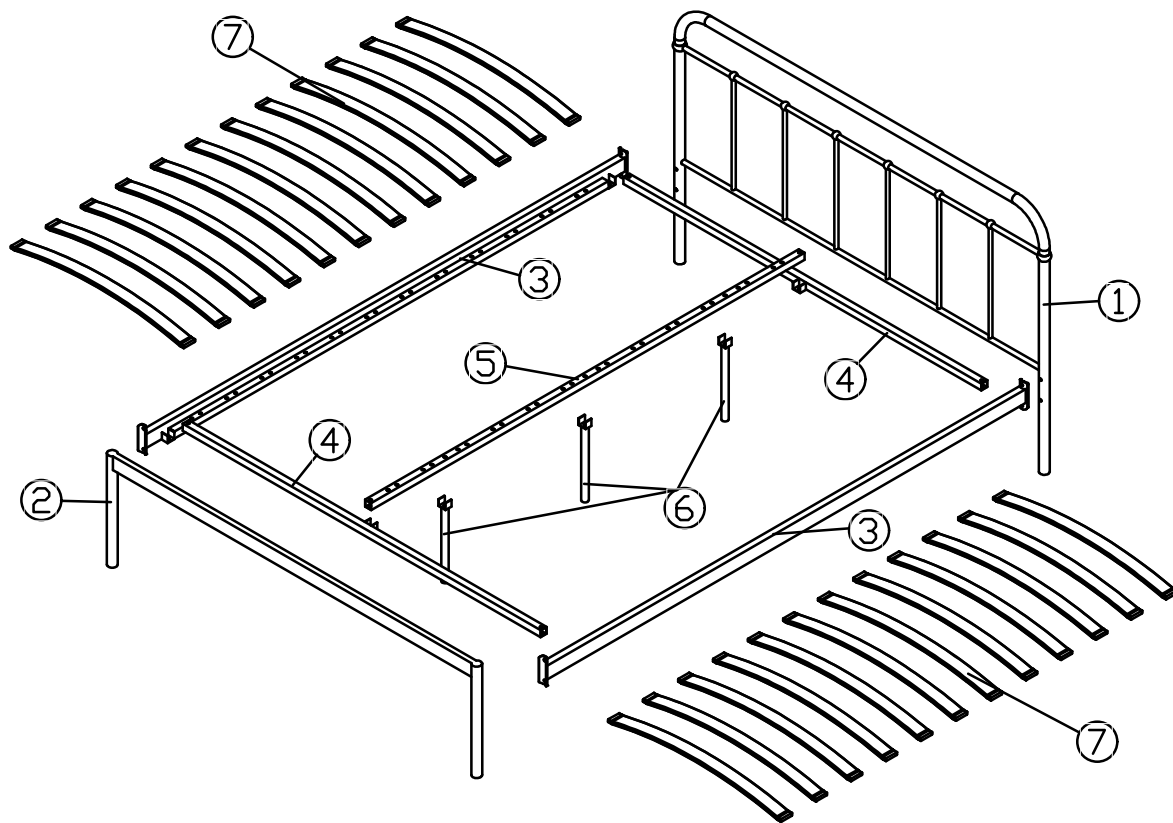

**Step by Step Guide to help build your Bed:**

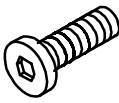
**(NOTE: You may find the steps below do not follow you actual instructions. This is a universal guide and may not match the steps provided within the instruction pack)**

1. Unpack all boxes. 1<sup>st</sup> step is to attach the Legs to the Headboard. Next step is attaching the Side Rails.
2. Attach one side rail at a time ensuring the pre-drilled holes on the side rails are facing upwards. Screw in loosely to begin with and when all side rails are aligned tighten up.
3. We now fit the cross bars by the headboard and footboard. These are metal bars which reach across the width of the bed and slot into the side rails. The bars must face upwards showing the groove in the middle of the bar open. This is so the central support bar can slot down into place on the next stage. (Note: Some slight force may be needed at this point)
4. Slot the central support Bar into the groove's in the middle of the cross bars (Note: Some slight force may be needed at this point)
5. There are 6 bolts and screws which now require putting in to tighten and secure the 3 bars just inserted. Please note that the screws are longer than required in most cases and the nuts must be tightened up the bolt so they are touching the metal frame work. They will become more difficult at one stage, this is due to the Nylon inside the nut to remove any squeaking between connections.
6. Now attach all central support feet (Note: the gap between flooring and leg is there for a reason, see FAQ on final page. (For Singles please move to next step)
7. We are now ready to place in the slats, they must be placed in curved upwards this helps support the mattress and provides extra comfort. They are fitted using the guide below:  
**(Small Double, Double, King: Side Rail>>Cap>>Slat>>Middle Cap<<Slat<<Cap<<Side Rail)**  
**(Singles: Side Rail>>Cap>>Slat<<Cap<<Side Rail)**
8. Once all slats are pushed in we can now ensure the whole bed is nice and secure by tightening any remaining bolts that have remained loose into the frame.
9. You can now place on the mattress (please note you may need 72 hours for the mattress to fully expand)
10. The Bed is now complete.

**It is important to remember that if you are experiencing any issues with this bed we are here to help you and will always do so as best and as quickly as we can. We are only a quick email away @ [info@crazypricebeds.com](mailto:info@crazypricebeds.com) please remember to reference your order number and attach any images to help us review what actions we need to take.**



<p><b>A</b></p>  <p>M8*20MM 8PCS</p>	<p><b>B</b></p>  <p>M6*35MM 9PCS</p>	<p><b>C</b></p>  <p>M6 6PCS</p>	<p><b>D</b></p>  <p>24PCS</p>	<p><b>E</b></p>  <p>12PCS</p>
<p><b>F</b></p>  <p>M4 1PCS</p>	<p><b>G</b></p>  <p>M5 1PCS</p>	<p><b>H</b></p>  <p>1PCS</p>	<p><b>I</b></p>  <p>3PCS</p>	

# STEP 1

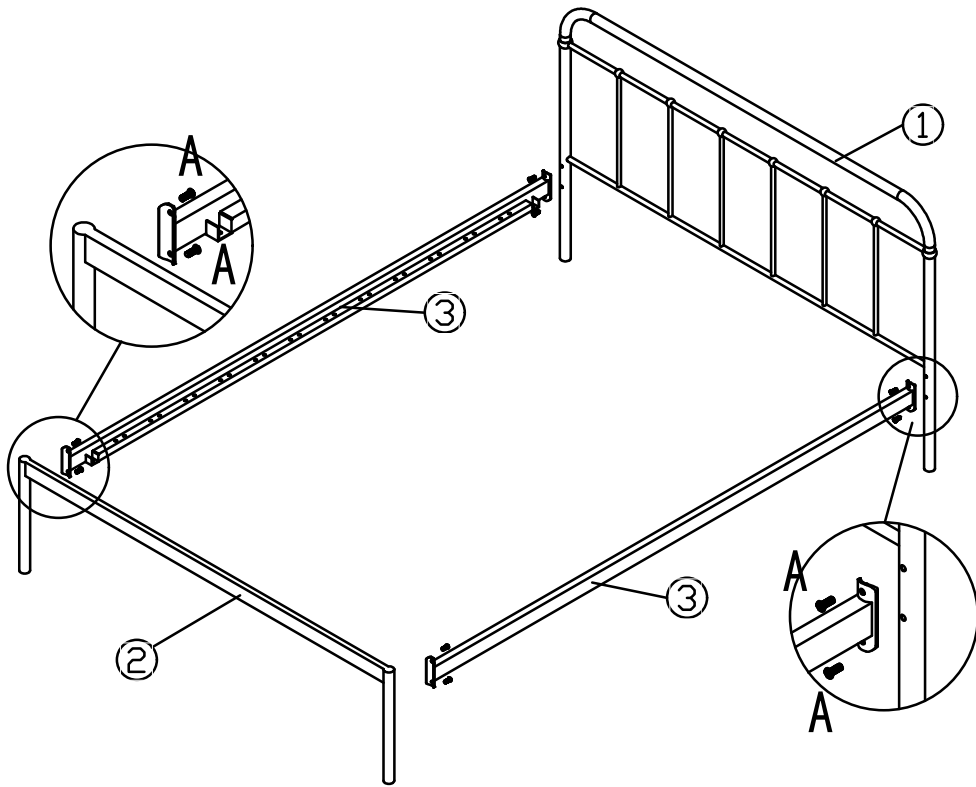

# STEP 2

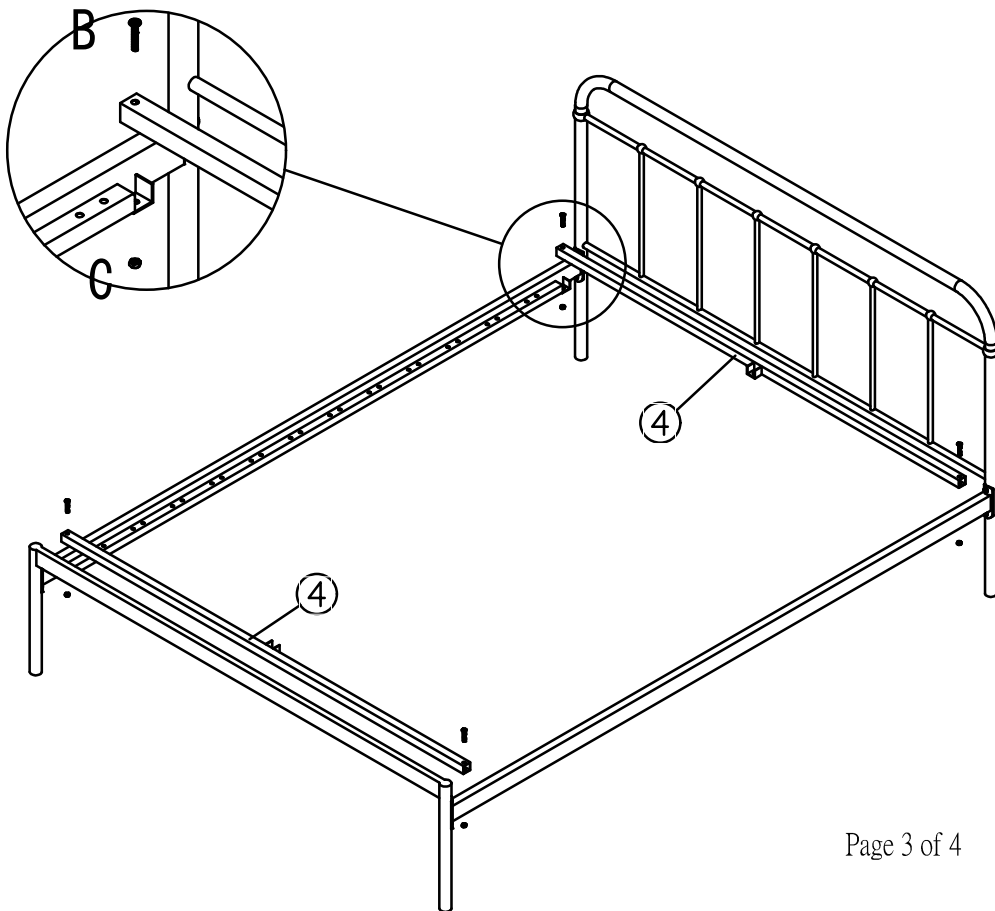

### STEP 3

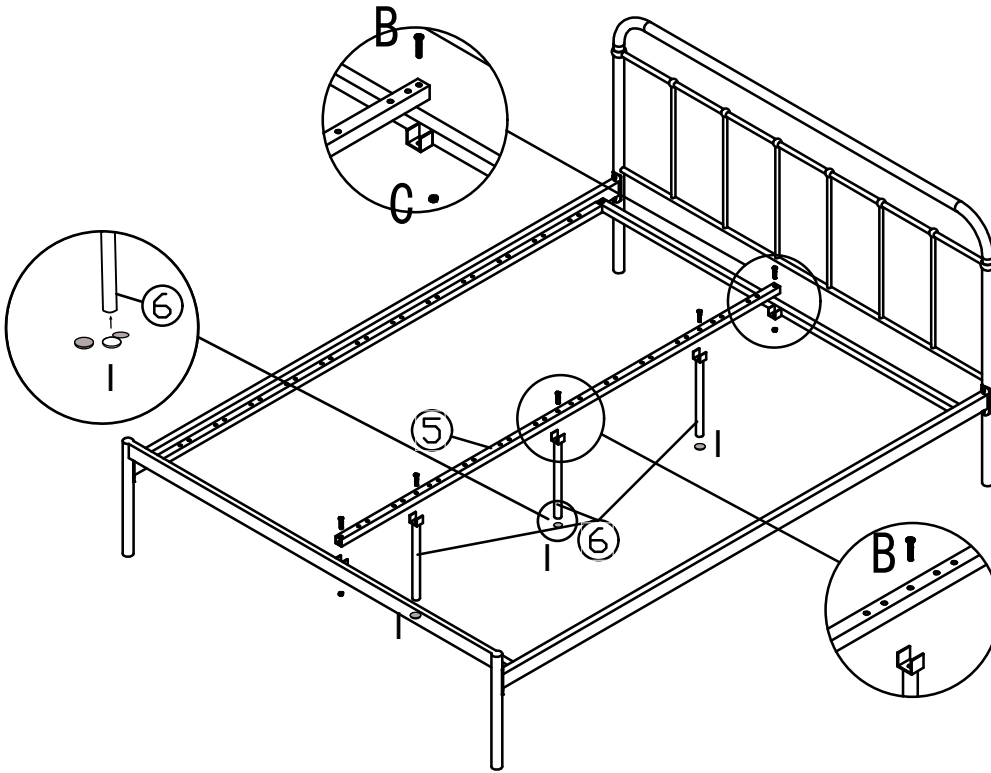

### STEP 4

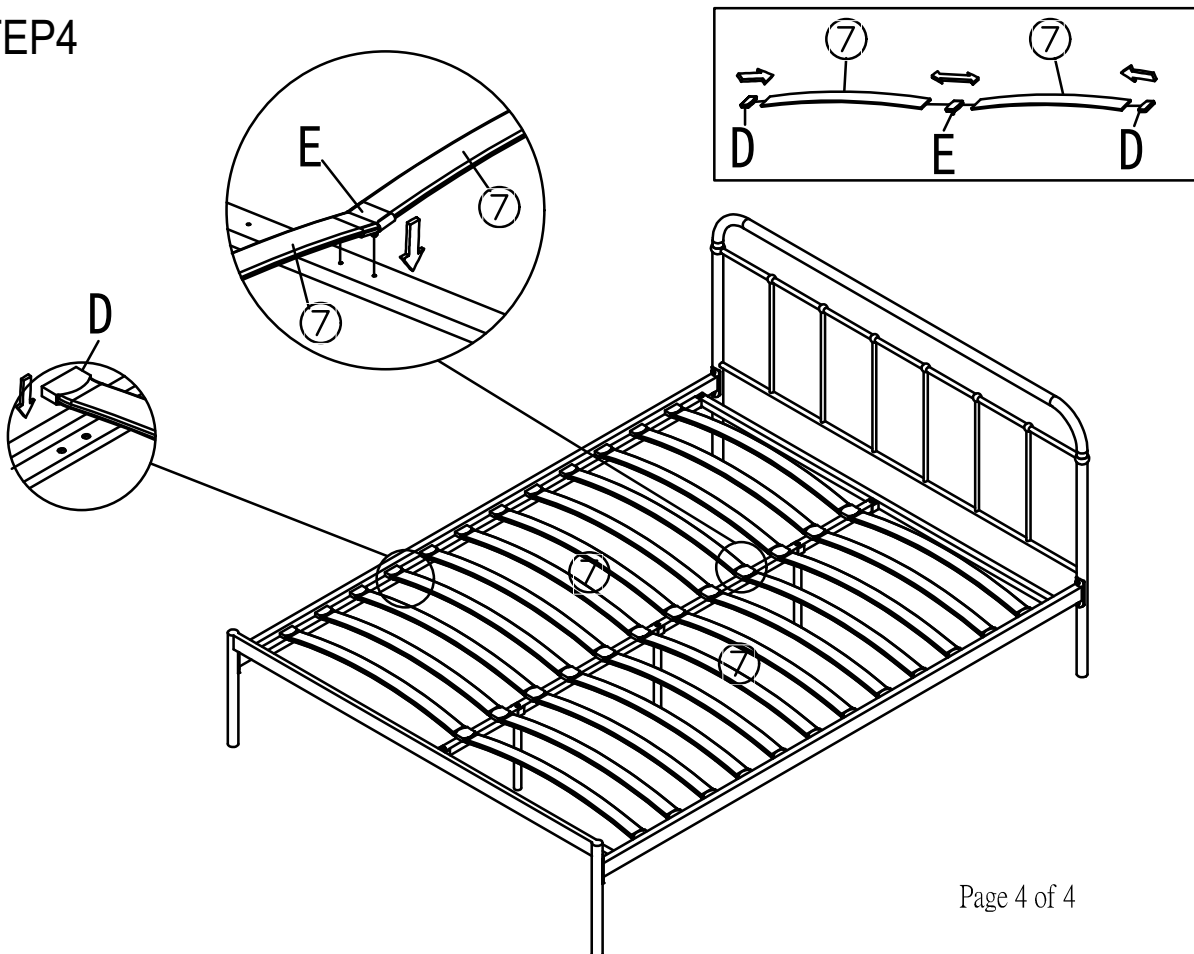

## **FAQ:**

### **Q. How long does this take to build?**

- A. We do recommend a 2 person build and the build on average takes approx. 1 hour

### **Q. My Hardware Pack Is Missing? What do I do?**

- A. Please re-check Box 1, this should be in a small palm sized plastic wrapped pack attached to the box with a piece of red string. If it is still missing please contact us @ [info@crazypricebeds.com](mailto:info@crazypricebeds.com) and one of our team will send you a new pack out as soon as possible.

### **Q. My Central Support Bar does not fit into the metal cross bars?**

- A. The most common issue here is a small effort required to push these into place to secure them into place before being bolted down. If this extra force doesn't solve your issue please send us an email with an image of your issue to [info@crazypricebeds.com](mailto:info@crazypricebeds.com) and one of our team will help you resolve the situation.

### **Q. I have missing parts or not enough parts? What should I do?**

- A. Please get in touch, we will want to resolve this issue as soon as possible by sending out replacement parts. Please reference the bed breakdown when contacting us as well as your order number and we will resolve this as quickly as possible.

### **Q. How do I fit in my Slats?**

- A. This frame has Sprung Slats which meet into the central support bar and are fitted in with Black caps. Please construct a complete length of slats. Push in the side sections of the slats then push down the middle cap into place. Your slats should be curved upwards. You should hear them click into place. For a Single this process will be different as they will attach on either side rail of the bed only.

### **Q. Why do the Central Support Legs not touch the floor?**

- A. It is important to note the slight gap is there for a reason. When people move the bed most likely some form of drag however slight may happen. This will cause the legs to bend and buckle. Causing the leg to become structurally in-effective and break this then in turn means the bed becomes unsafe to use. Having the gap prevents this.

### **Q. My Headboard is very low. Why is this?**

- A. You will need to place and bolt in to place the headboard legs. These simply slot into the headboard and are bolted in by to small bolts on either leg. Once this is done your headboard will have the height required.

### **Q. Which way do I put in my Central Support Bar?**

- A. You may be asking this if you have a single frame. Put simply in the single you can have the support bar either way i.e. pre-drilled holes facing upwards or downward, either way will not affect the structure of the bed. On the Double and King you will need the pre-drilled holes facing upwards as this is where the middle slat caps will be pushed into.

**If you do have any further questions or queries we have not covered above please get in touch and we will be happy to help.**